

1200M "C Case" Retro Motor Deadlatch

SteelCell LOCKS
ENGINEERED LOCKING SYSTEMS

ELECTRO-MECHANICAL LOCKS

- Jamb Mounted For Swing Doors
- Key: Mogul
- Security: Medium/Maximum
- Motor Operated

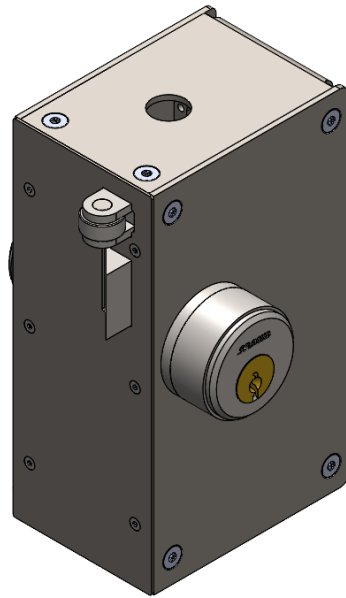

Replaces: Folger Lock 3 1/2" x 5 1/4" x 9 1/4" Internal Mount

Optional



ASSA Key

Optional



Mogul Assa Cylinder

APPLICATIONS

The 1200M Retro is a motor operated pin tumbler lock for a variety of swing door applications, such as inmate rooms, housing and dayroom perimeter doors, corridors and some exterior doors.

OPERATION DETAILS

The 1200M deadlatch is a motor operated lock. When the door is in a locked closed condition, the latch bolt is deadlocked preventing the latch bolt from being retracted. Once the motor is energized, the deadlatch is lifted and the latch bolt is allowed to retract, unlocking the lock.

The motor is equipped with a motor switch that allows for a full cycle operation. Full cycle (M) operation uses a momentary contact switch to rotate the motor 360 degrees and unlock the lock.

Once the door opens, the latch will project and the lock will return to a locked condition once the door is closed.

Full cycle typically uses the "Mechanical Holdback" feature which allows the bolt to be retracted until the door opens.

The deadlock indicator switch provides monitoring of the deadlocked condition as well as the full projection of the latch bolt.

SteelCell LOCKS
ENGINEERED LOCKING SYSTEMS

P: 706-778-9615

E: locks@steelcell.com

W: www.steelcelllocks.com

510 Industrial Park Road
Baldwin, GA 30511
United States

Formerly approved as Midwest Portland

1200M "C Case" Retro Motor Deadlatch

Standard Features

- 120 VAC or 24 VDC Motor
- 3/4" Throw Latchbolt
- Investment Cast Backplate
- Universal Cylinder Collar(s)
- Deadlock Indicator Switch
- Heavy Duty Construction
- Corrosive Resistant Parts
- Internal Mounting Holes
- Manual Key Release
- Easy Wiring Field Plug
- Investment Cast Strike Plate

Component Specifications

- Motor - 120 VAC 60hz
- Reinforced Backplate - 1/4" Investment Cast Stainless Steel
- 10 Gauge Steel - Zinc Plated Case & Cover
- Latchbolt - Tool Resistant Investment Cast Stainless Steel
- Rollerbolt - Tool Resistant Investment Cast Stainless Steel
- Strike - Investment Cast Stainless Steel
- Deadlock Lever - 1/4" Zinc Plated Steel
- Operating Lever - 1/4" Zinc Plated Steel
- Springs - Stainless Steel

Keying

(See Handing Chart Guide)

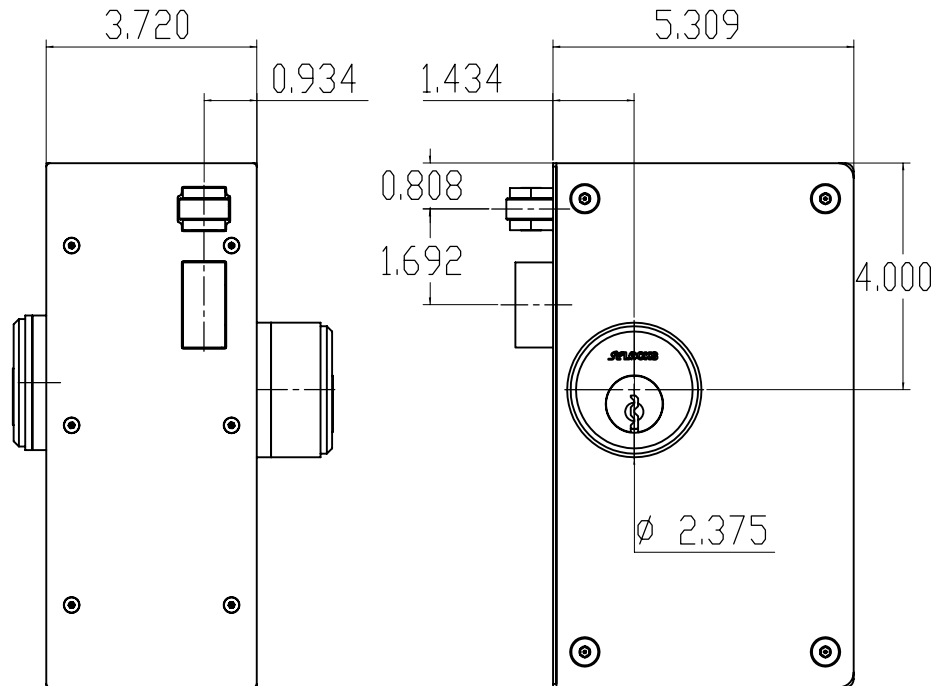
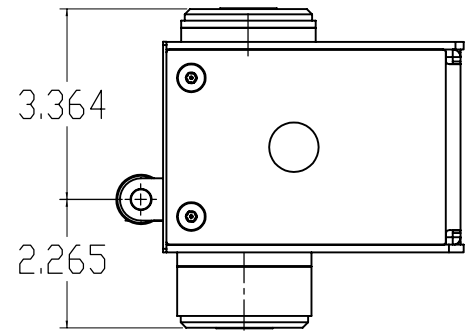

THIS ILLUSTRATION IS FOR INFORMATIONAL USE ONLY. DO NOT USE FOR CONSTRUCTION.

Operation

Latch unlocks by momentary switch action or latch may remain retracted by continuous duty motor.

CHOICE OF FUNCTION:

Mechanical Holdback (Standard) - Once unlocked, the latchbolt is held retracted until the door opens. The latchbolt then projects and allows the door to be slam locked.

OR:

Non-Holdback (Optional) - Latchbolt retracts only as long as power is applied to the motor.

Optional Features

Knob Release - Opposite side of cylinder provides retraction of latchbolt at any time.

External Mount - Available upon request.