

1200MC "D Case" Retro Motor Deadlatch

SteelCell LOCKS
ENGINEERED LOCKING SYSTEMS

ELECTRO-MECHANICAL LOCKS

- Jamb Mounted For Swing Doors
- Key: Mogul
- Security: Medium/Maximum
- Motor Operated

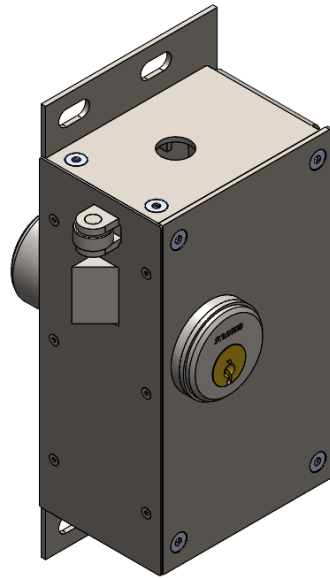

Replaces: Southern Lock 3 1/2" x 5 1/4" x 9 1/4" - External Mount

Optional



ASSA Key

Optional



Mogul Assa Cylinder

APPLICATIONS

The 1200M Retro is a motor operated pin tumbler lock for a variety of swing door applications, such as inmate rooms, housing and dayroom perimeter doors, corridors and some exterior doors.

OPERATION DETAILS

The 1200MC deadlatch is a motor operated lock. When the door is in a locked closed condition, the latchbolt is deadlocked preventing the latchbolt from being retracted. Once the motor is energized, the deadlatch is lifted and the latchbolt is allowed to retract, unlocking the lock.

The motor is equipped with a motor switch that allows for a half cycle operation. The half cycle (MC) operation uses a two position switch. The 1st switch position rotates the motor half way and unlocks the lock.

The lock will remain unlocked until the 2nd switch position rotates the lock and returns to a locked condition with the latch projected, once the door is closed.

Half cycle uses "Non-Holdback", which holds the bolt back only during the half cycle position.

The deadlock indicator switch provides monitoring of the deadlocked condition as well as the full projection of the latchbolt.

SteelCell LOCKS
ENGINEERED LOCKING SYSTEMS

P: 706-778-9615

E: locks@steelcell.com

W: www.steelcelllocks.com

510 Industrial Park Road
Baldwin, GA 30511
United States

Formerly approved as Midwest Portland

1200MC "D Case" Retro Motor Deadlatch

Standard Features

- 120 VAC or 24 VDC Motor
- 3/4" Throw Latchbolt
- Investment Cast Backplate
- Universal Cylinder Collar(s)
- Deadlock Indicator Switch
- Heavy Duty Construction
- Corrosive Resistant Parts
- External Mounting Plate
- Manual Key Release
- Easy Wiring Field Plug
- Investment Cast Strike Plate

Component Specifications

- Motor - 120 VAC 60hz
- Reinforced Backplate - 1/4" Investment Cast Stainless Steel
- 10 Gauge Steel - Zinc Plated Case & Cover
- Latchbolt - Tool Resistant Investment Cast Stainless Steel
- Rollerbolt - Tool Resistant Investment Cast Stainless Steel
- Strike - Investment Cast Stainless Steel
- Deadlock Lever - 1/4" Zinc Plated Steel
- Operating Lever - 1/4" Zinc Plated Steel
- Springs - Stainless Steel

Keying

(See Handing Chart Guide)

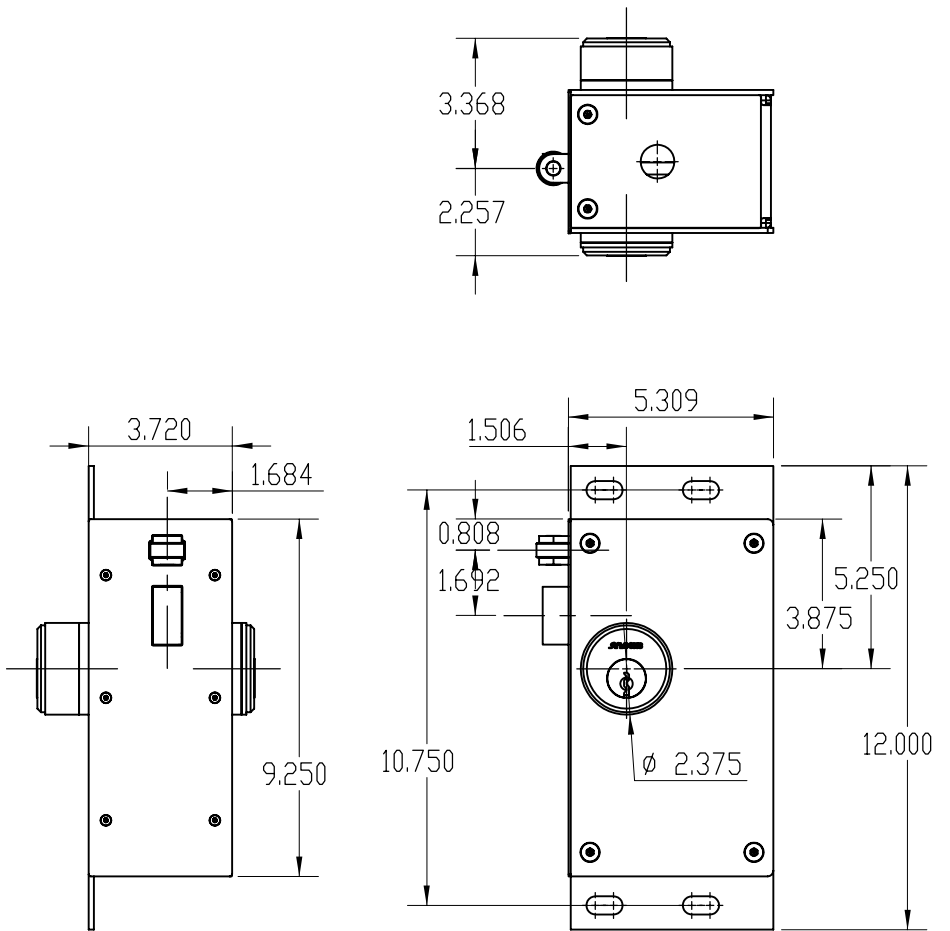

THIS ILLUSTRATION IS FOR INFORMATIONAL USE ONLY. DO NOT USE FOR CONSTRUCTION.

Operation

Latch retracts and remains retracted by first position of two-position switch. Latch projects for relocking by second position of two-position switch.

Optional Features

Knob Release - Opposite side of cylinder provides retraction of latchbolt at any time.